

# Packaging of Espresso capsules into folding cartons

## Feeding of nested Espresso capsules.



Coffee and espresso machines are currently experiencing an enormous boom, because they have also become affordable for the consumer. Höfliger provides a cartoning machine for espresso capsules that are obtainable in the retail trade in ten different flavors. Ten nested capsules each are fed and inserted into the erected carton without any damage. It is then closed with hotmelt glue.

### The requirements of the machine:

- Processing of a carton with extreme dimensional ratios (the difficulty here is the erection of a square carton blank)
- Special product handling of espresso capsules, consisting of very pressure-sensitive aluminum
- Sophisticated 2-lane feed solution with nesting device by means of an S-type accumulation segment and sorting unit for ten nested capsules

### Other features:

- Secure product insertion and carton closure by means of hotmelt glue
- The bulk pack is opened via a perforated tear-open aid by the consumer



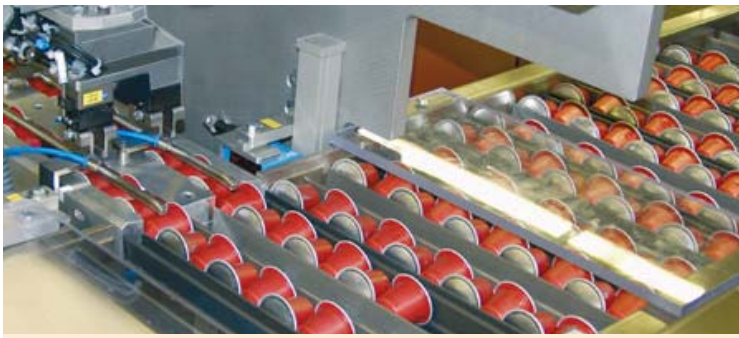

Feeding of espresso capsules

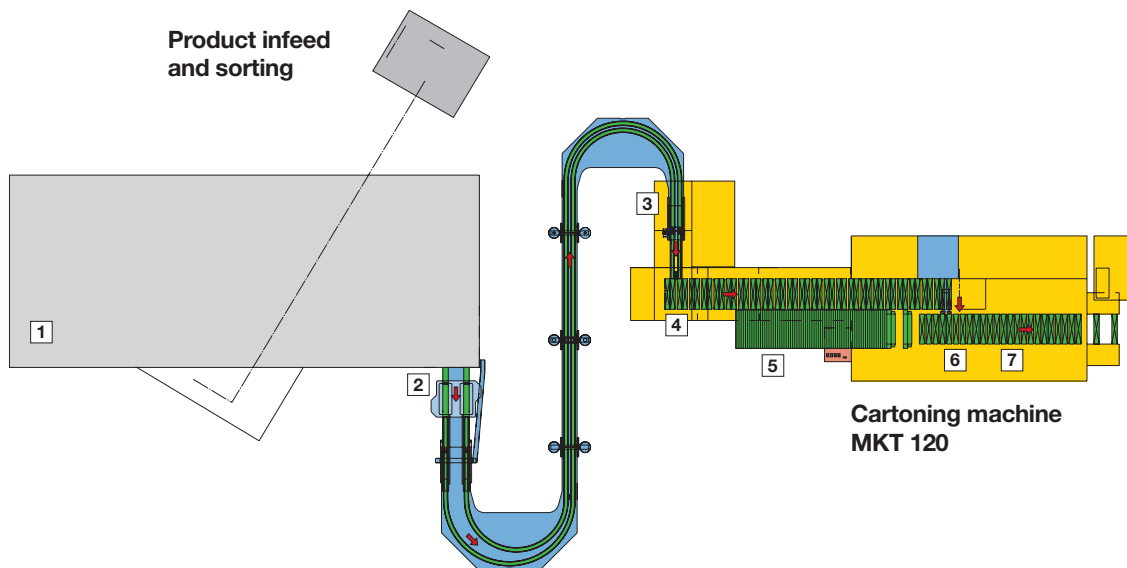

**Technical data**

**Output:**

up to 600 capsules / minute  
 up to 40 cartons / minute (single insertion)  
 up to 80 cartons / minute (double insertion)

**Production sequence**

- |  |   |
|--|---|
| <b>1</b> Feeding of espresso capsules                              | <b>5</b> Feeding and erection of cartons            |
| <b>2</b> Nesting of the capsules and sorting into the feed segment | <b>6</b> Insertion of capsules into erected cartons |
| <b>3</b> Portioning of 10 capsules                                 | <b>7</b> Carton hotmelt glue closure                |
| <b>4</b> Overfeeding of capsules into the product chain            |   |